

# CACHFIRES

## FOCO ROOM DIVIDER 1000 - BIOCAMINO DIVISORIO

BIO-30-111

Il biocamino Foco Room Divider 1000 è un elegante camino a bioetanolo incassato progettato per pareti divisorie, che consente di ammirare le fiamme da tre lati. Con una larghezza di 100 cm, questo camino crea un effetto visivo raffinato e un'atmosfera accogliente nella stanza. Scegli tra un bruciatore a bioetanolo manuale o automatico, per un comfort ottimale e un facile utilizzo. Realizzato in acciaio inossidabile verniciato a polvere di 4 mm e dotato di vetro temperato, il Foco Room Divider garantisce un'esperienza di fiamma stabile e un design senza tempo.

### SPECIFICHE TECNICHE

#### Bruciatore

Dimensioni minime della stanza	80 m <sup>3</sup>
Fiamme regolabili	Sì
Controllo	Telecomando
Controllo	Automatico
Controllo	Manuale
Modello di bruciatore	4 litri Superior
Lunghezza della fiamma	60 cm
Telecomando	Sì (componente aggiuntivo)
Potenza (Max)	4,4 kW
Consumo	0,62 l/ore

#### Dimensione

Lunghezza	100 cm
Altezza	50 cm
Profondità	40 cm
Peso	25 kg

#### Aspetto esteriore

Materiale	Acciaio
Spessore dell'acciaio	4 mm
Colore	Nero
Vetro incluso	Sì

#### Modello

Tipo di carburante	Bioetanolo
Tipo di prodotto	Camino a bioetanolo da incasso trifacciale
Marchio	Foco
Canna fumaria	Non necessaria
Uso	Al chiuso
Vista delle fiamme	Divisorio
Garanzia	2 Anni
Tasso di ricambio d'aria consigliato	1



### Automatic burner 700

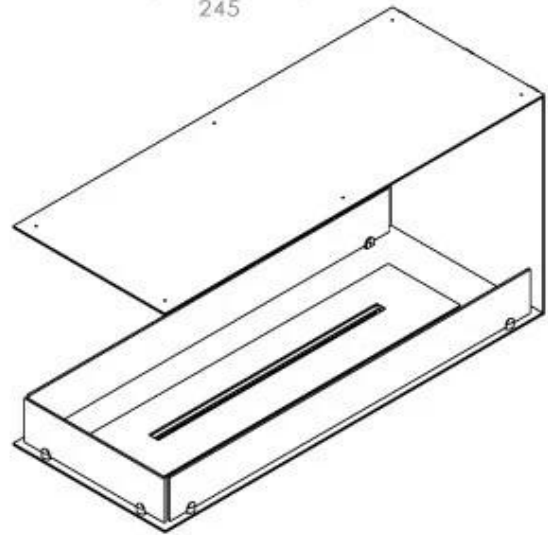
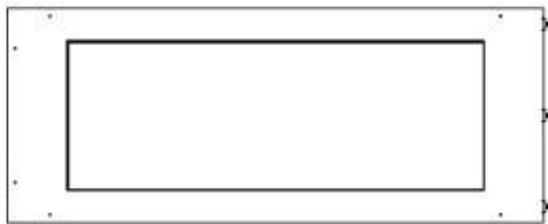
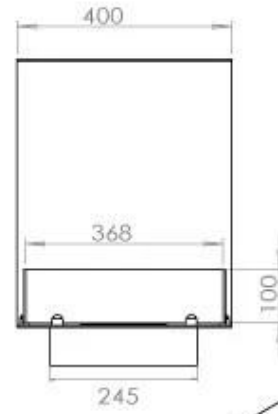
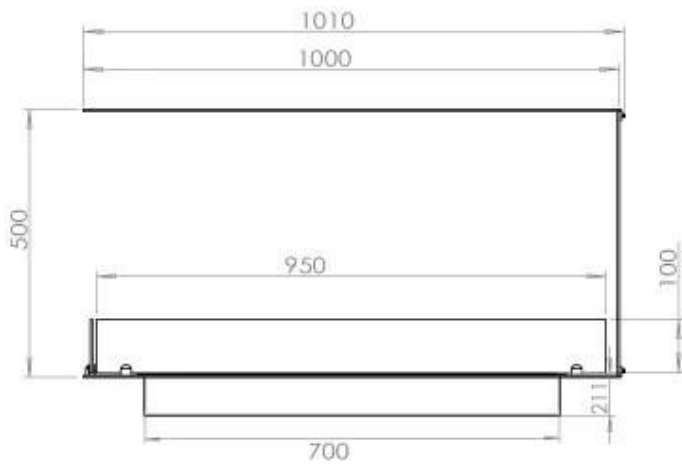

### PrimeFire 700

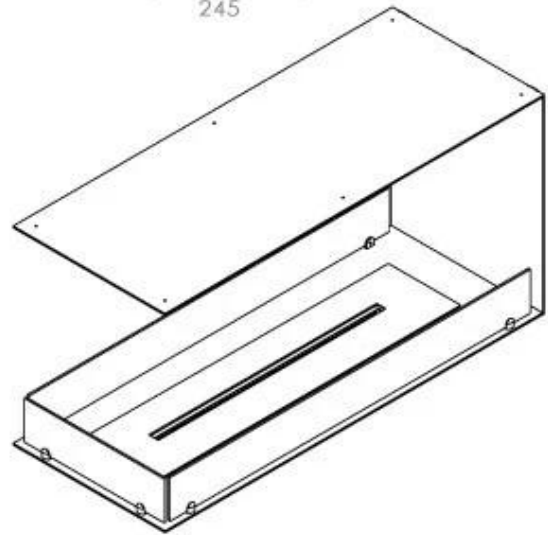
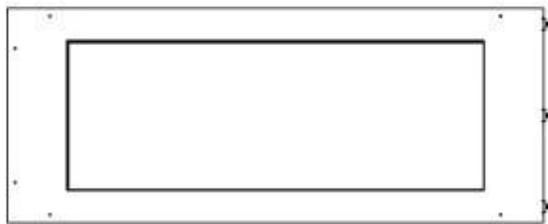
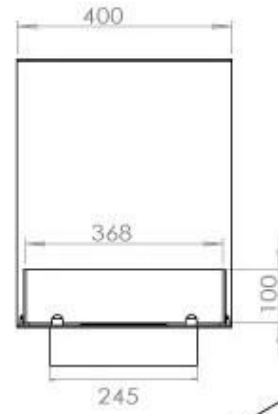
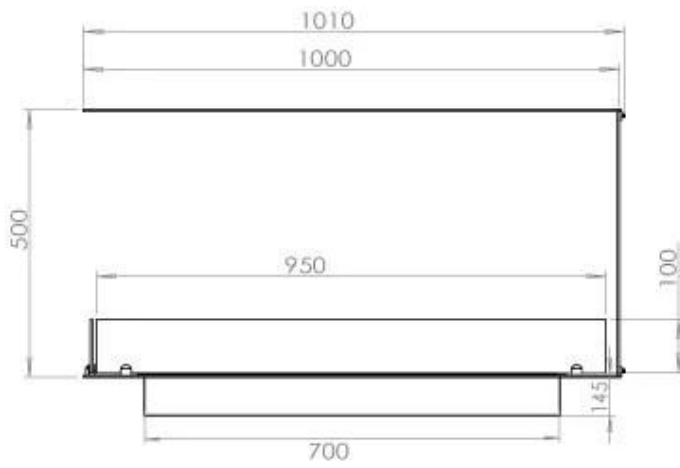

**FLA 3 790 mm**

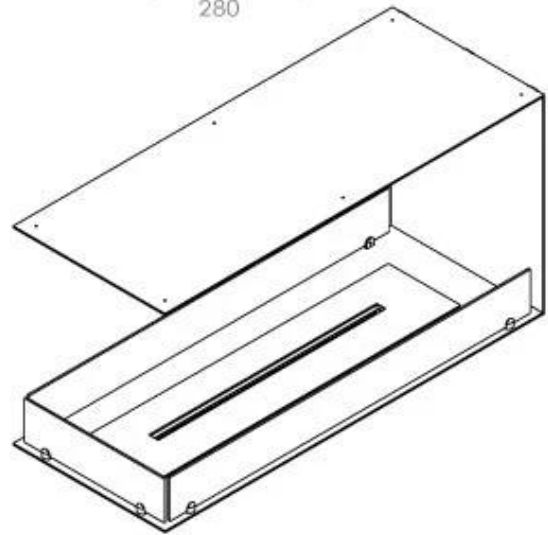
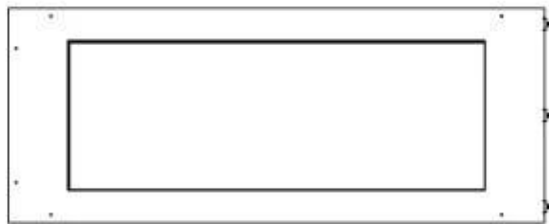
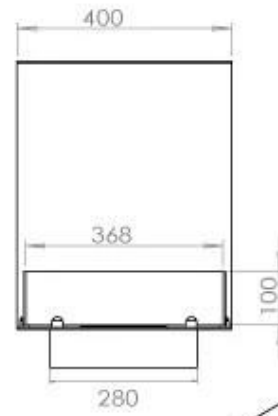
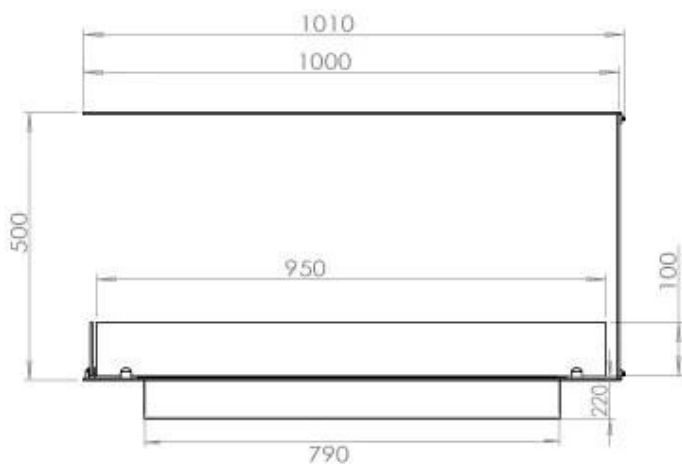

**FLA 3+ 790 mm**

